

"When you have eliminated the impossible, whatever remains, however improbable, must be the truth."

—Sherlock Holmes

The greatest cover-up of all

By Robert Sam Anson

It was one of those coincidences. No one could have known that the bus would be stopping in front of Jacqueline Kennedy's apartment at precisely the moment she would be walking through the front door on her way to yet another funeral, but there, bizarrely, macabrely, it was: the bus with the big ad spread across its side, announcing in two-foot-high letters that "Lee Harvey Oswald Was Innocent." For a moment, there was an embarrassed silence. All that indicated recognition was a slight widening of the eyes and an almost imperceptible tightening of the muscles of her face. And then she was gone, disappearing in her limousine.

Even now, 11 and a half years since that sunny day in Dallas, it is the murder no one will ever forget. Two presidents have come and gone, a war, rebellions, changes without number. And still the image persists. A young president, pledged "to do better," riding in an open limousine, waving to cheering crowds. A turn, then another turn, and the car is heading past a tall building, slowly gliding toward the tunnel that lies just beyond a grassy knoll. The wife of the governor turns toward him and smiles. "You can't say the people of Dallas don't love you, Mr. President." There is no answer, only a sharp, popping

noise, a sound like firecrackers. In that moment everything changes.

The furies that were released with the assassination of John Fitzgerald Kennedy have never gone away. Nor have the doubts that have surrounded the circumstances of his killing. The Warren Com-

The "dirty rumors" the Warren Commission tried to squash have not gone away. Now Watergate and new evidence have forced another look. The conclusion: a conspiracy for sure

mission's verdict that a "deranged" young man named Lee Harvey Oswald, acting alone, murdered President Kennedy and seriously wounded Governor John Connally, only to be killed himself two days later by another deranged, lone assassin named Jack Ruby, raised as many questions as it answered. Two years after the

publication of the commission's findings—a report and 26 volumes of documents and testimony, based on 25,000 interviews—the Gallup and Harris polls found that nearly two-thirds of the American people disbelieved its conclusions.

They were not the only doubters. Lyndon Johnson, who had appointed the commission, went to his grave believing that his predecessor had been the victim of a "communist" conspiracy. John Connally loudly proclaimed his objections to the commission's finding that he had been wounded by the same bullet that had allegedly passed through the President's throat. The commission's version of Connally's wounding was crucial, since, as one commission lawyer put it, "more shots means more assassins." Several members of the commission itself were less than convinced of the accuracy of the report they signed. Rep. Hale Boggs of Louisiana, a commission member, was particularly upset by many of the findings and wanted to issue a minority report, until the commission agreed to insert "probables" in front of many items that had been marked certainties. Even so, Boggs was less than satisfied. Until his mysterious disappearance in a light plane flying over Alaska in 1972, he continued to tell friends that the Warren Commission was in error. Similarly, the late Senator Richard Russell, who had been placed on the commission in deference to his power as chairman of the Armed Ser-

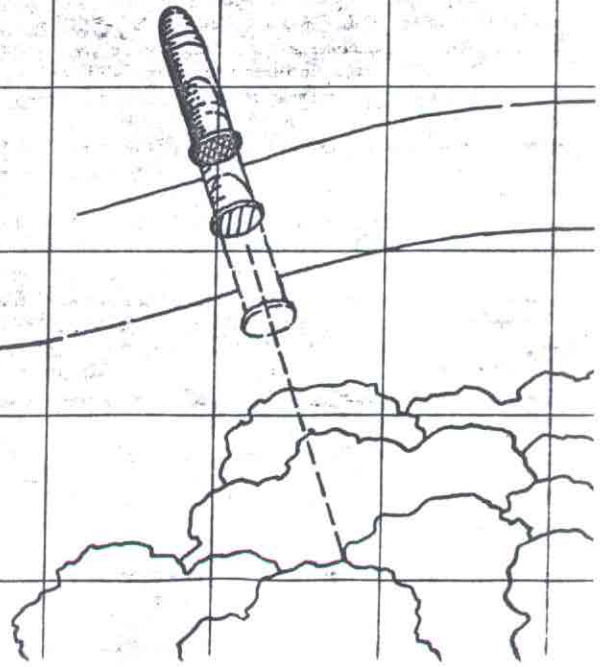
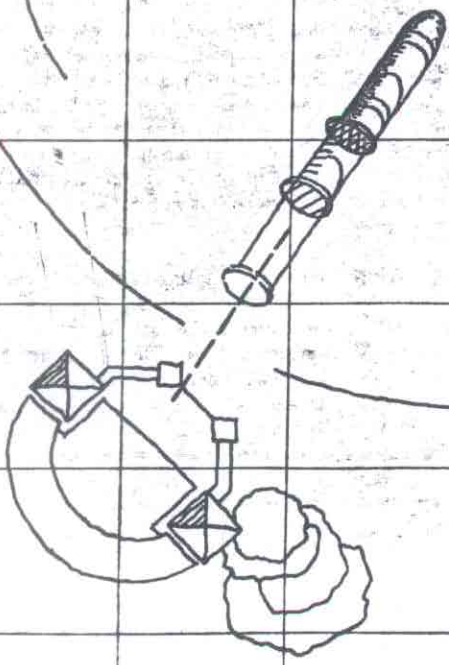
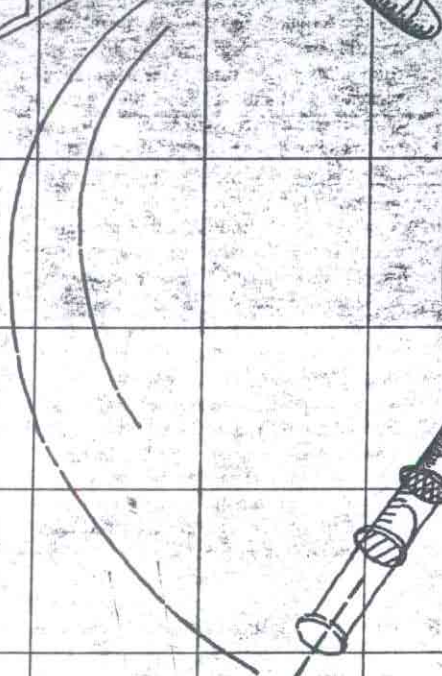
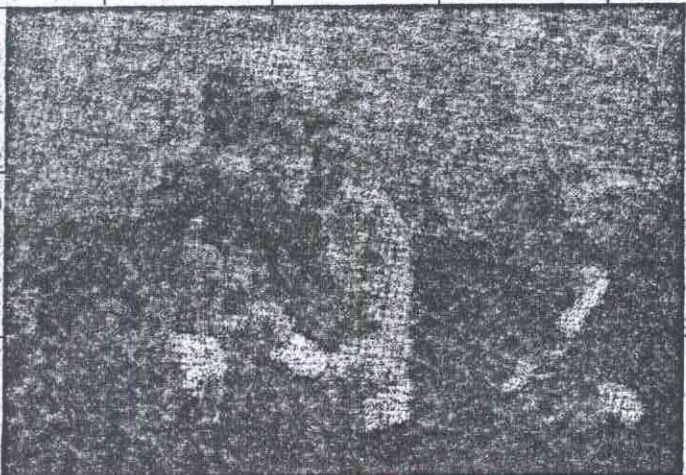

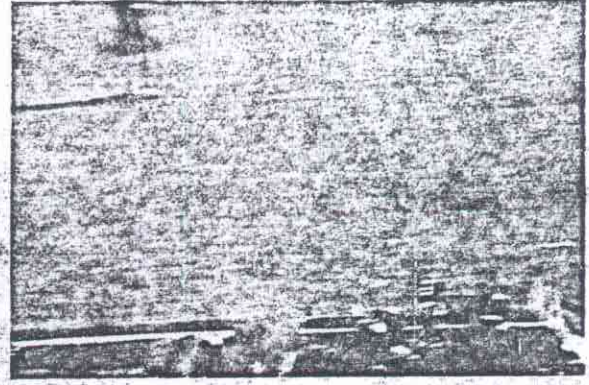
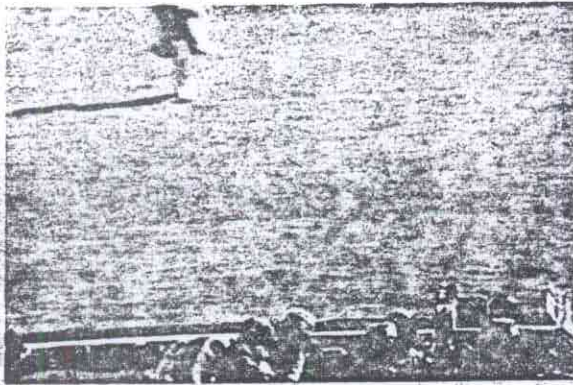

vices Committee, made slight secret of his disenchantment with the commission's report and encouraged private investigators to challenge its findings. "I never believed that he [Oswald] did it without any consultation or encouragement whatsoever," Russell said in 1970. "Too many things caused me to doubt that he planned it all by himself." And then there were the witnesses to the assassination itself. Fifty-two of them insisted that at least some of the shots that killed President Kennedy came from in front of him, from the direction of the infamous grassy knoll. The commission discounted all of them.

Small wonder, then, that the commission's report proved a breeding ground for skeptics. In the years immediately following the assassination, 26 books and dozens of articles, some of them serious, some simply scurrilous, challenged the finding that Oswald acted alone or, in the opinion of many of the doubters—including Mark Lane and Sylvia Meagher, author of the seminal *Accessories After the Fact*—at all. By 1967, the holes in the Warren Commission report had become so numerous and obvious, and the public furor about them so great, that several congressmen were demanding a new investigation. Then, another one of those coincidences. In New Orleans a district attorney named Jim Garrison, a figure of large ambition and unsavory reputation, indicted Clay Shaw, director of the New Orleans Trade Mart, for conspiracy to murder John Kennedy. Garrison claimed that Shaw was the ringleader of a CIA cabal. He proved only that Clay was a devotee of kinky homosexuality. After a ludicrous trial, in which Garrison made almost no attempt to produce evidence, Shaw was acquitted. Subsequently, Shaw died and Garrison was driven from office. The Warren Commission's critics were scattered in disarray.

Now the critics have returned, stronger than before. Armed with sophis-

ticated new technology and a raft of Freedom of Information lawsuits, they have uncovered additional evidence pointing to the existence of a conspiracy—a conspiracy in which Lee Harvey Oswald was not involved, if indeed there ever was a Lee Harvey Oswald. Within the last few months, Congressman Henry Gonzalez, a Democrat from San Antonio, has introduced a resolution calling for a congressional investigation of the assassination. A petition backing it has collected more than 250,000 signatures on the West Coast alone. A bootlegged copy of the long-suppressed Zapruder film, showing President Kennedy being driven violently backward by a shot that rips off the top of his head, has been shown on national television twice. Perhaps most significant of all, the Justice Department, according to reliable sources, has very quietly begun a high-level, internal review of Oswald's background. In the past, rumors have circulated that Oswald was an agent of one or more intelligence agencies, perhaps including the FBI. Now, the rumors are taking on some substance.

Much of the evidence that is being gone over today is precisely the same ground that the critics went over a decade ago. What has changed is belief. The strongest selling point of the Warren Commission is not what it said but the people who said it: some of the most respected men in the land, among them the chief justice of the United States, two directors of the CIA and a man who a decade later would assume the presidency, Gerald R. Ford. If a senior public figure stated something in 1964, there was a tendency to take him at his word. In the aftermath of Watergate and Vietnam, few people are prepared to believe anything that comes out of Washington. In a sense, that is part of the problem. As Mark Lane, who has returned to investigating the assassination after sojourns into Vietnam protests and Indian rights struggles, puts it: "It's not a question any longer of persuading people to disbelieve the War-

ren Commission report. They are ready to believe almost any explanation, however crazy, as long as it doesn't come from the government."

The proposition that Oswald *wasn't* acting alone has always seemed a little crazy. Because, if he wasn't, then there must have been a conspiracy, a word that does not go down easily among many Americans. And, if there was a conspiracy, then there must have been an effort to cover it up, an effort so monumental that it would have had to include the Dallas police, the CIA, the Secret Service, the FBI and, yes, possibly the President of the United States. Ten years ago, that was a little hard to swallow. Even now, it is a story one would rather not believe. But there are the questions that won't go away. And there is Watergate: a conspiracy involving the CIA, the FBI, the Department of Justice and, yes, the President of the United States. Suddenly, it becomes possible.

The commission and the critics

Impossible, said the commission, from the moment it began its work. Conspiracy was the one thing the commission did not want to hear, much less discover. Earl Warren, who had accepted the chairmanship of the commission only after considerable arm-twisting from President Johnson, made it clear at the first, secret staff meeting of the commission that his mission and theirs was more political than investigatory. He had taken the job, Warren told the commission, because the President had convinced him that if rumors about a conspiracy were not squelched, it could conceivably lead the country into war. As Melvin Eisenberg, a commission lawyer, later recalled the chief justice's charge in a memo, "He placed emphasis on quenching rumors, and precluding further speculation such as that which has surrounded the death of Lincoln."

Thus, under extreme political pressures, the commission set about its task.

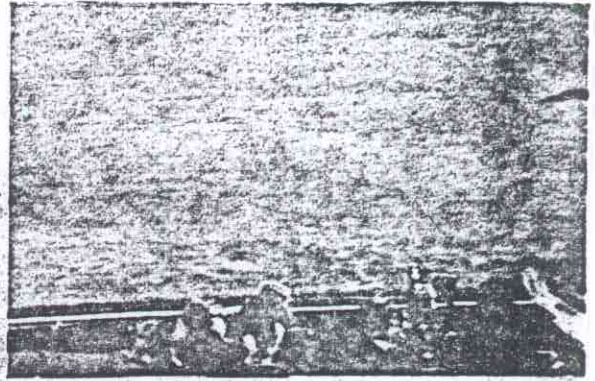
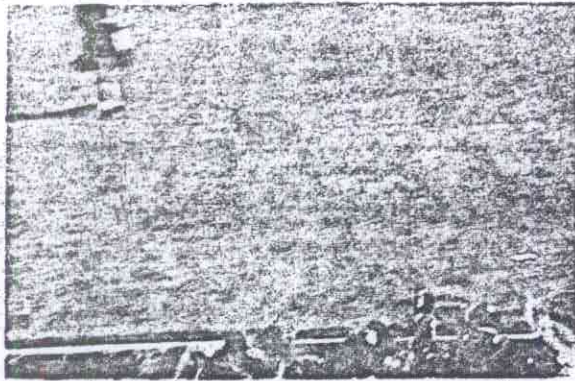

With no investigative staff of its own, it relied on the FBI and CIA to do its field work for it. At times, the reliance proved embarrassing, as when the FBI report came in stating that President Kennedy and Governor Connally had been wounded by separate shots. The FBI version of the President's wounds also differed sharply from the commission's version, which later was condemned by the American Academy of Forensic Pathologists as being so incomplete and sloppy as to be no autopsy at all. The FBI's placement of the President's wounds—one in the head, another some six inches below the neck—made the commission's scenario of events untenable. Secret Service men who witnessed both the shooting and the autopsy also placed the back wound well below the neck, as did the autopsy doctors' own diagram. The President's jacket and shirt also showed a bullet hole just beneath the shoulder. Faced with such evidence, the commission chose the only practicable course: it ignored it.

Instead, the commission's junior lawyers came up with their own theory of the assassination, one contradicted by ballistics findings, autopsy results and the testimony of every witness to the actual event. In time, it came to be called "the magic bullet theory."

Simply stated, the commission found that three bullets were fired that day in Dealey Plaza, all from the rear. The final, fatal shot hit the President in the back of the head. The second shot missed completely and struck the pavement, wounding a bystander. The first, the "magic" bullet, struck President Kennedy in the back just below the neck, passed through his neck into the back of Governor Connally, smashed through Connally's rib and out his chest below his right nipple, and continued on to strike his wrist, finally winding up in Connally's thigh. In short, one shot, seven holes.

If there were only one assassin, firing from the sixth floor of the School Book Depository, the commission's the-

ory made sense. Indeed, it was the only theory that could account for a lone assassin, since the alleged murder weapon, a 1940 vintage Italian-made Mannlicher-Carcano, was a clumsy, single shot, difficult to operate weapon. Tests conducted by the commission determined that it was physically impossible to shoot and load the Carcano more than three times in the 5.6 seconds between the first time the President was hit and the final, fatal shot.

The trouble began when the commission attempted to duplicate Oswald's alleged marksmanship. First, they found that the rifle was fitted with a left-handed scope; Oswald was right-handed. Then, too, shims had to be inserted to make the scope accurate. Ignoring the fact that Oswald's Marine records showed him to be a

A petition backing a reinvestigation has collected more than 250,000 signatures on the West Coast alone

poor shot, the commission had three master marksmen from the National Rifle Association recreate the events in Dallas by hitting a level, stationary target. None of them could. Of course, Oswald could have been lucky. As for the one and a half seconds that elapse between the time the Zapruder film shows the President to be hit and Governor Connally bunching up and slumping over, the commission suggested that Connally was merely experiencing a "delayed reaction" to having his chest torn open by a high-powered rifle bullet.

Totally inexplicable is how the bullet that purportedly did all this damage (and was later conveniently discovered on the governor's stretcher in a corridor of Parkland Hospital) emerged so

miraculously intact, virtually undeformed, with only 2.5 grains missing from its normal weight. The commission itself had a similar bullet fired into the wrist bone of a cadaver and found that the bullet was mangled.

The most damning evidence, though, comes from the most unlikely source: J. Edgar Hoover. In a letter to the commission not included in the original 26 volumes of evidence and testimony, Hoover reveals that the magic bullet and bullet fragments were subsequently subjected to spectrographic analysis. That test, Hoover reports, was inconclusive. However, there was an additional test, a Neutron Activation Analysis, a highly sophisticated technique that measures the differences in material that has been bombarded with radiation down to parts per billion and sometimes even less. In his letter to the commission, Hoover blandly reports that while "minor variations" were found between the fragments taken from President Kennedy's body and those taken from Governor Connally's body, those differences were not judged to be "sufficient." To the layman, that explanation sounds fine, and certainly the commission did not question it. But the beauty of NAA is that the size of differences between particles are meaningless. Virtually any difference, however minute, is not only "sufficient" but irrefutable. Unless atoms changed their structure that day in Dallas, John Kennedy and John Connally were wounded by separate bullets.

Perhaps the subtleties of neutrons and atoms may have escaped the members of the commission. Incredibly, no mention of the NAA test or Hoover's letter is to be found either in the report or the 26 volumes of evidence (so far the FBI has refused to release copies of the actual NAA findings). Far more graphic evidence, however, was right in front of them: a color film of the assassination itself.

Abraham Zapruder, a Dallas dress

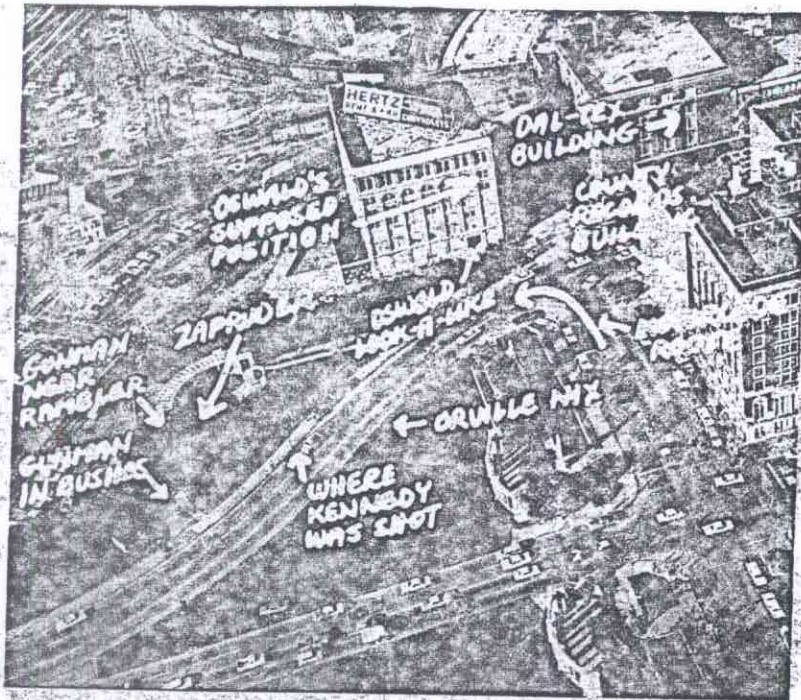

Just as I did, he [the man at whom Smith had been pointing his weapon] showed me he was a Secret Service agent." There is only one problem. The Secret Service's own records show there were no Secret Service men on the grassy knoll.

Indeed, a lot of people were where they shouldn't have been that day. Winston Lawson, the Secret Service agent responsible for the choice of the Kennedy motorcade route, later reported that motorcycle outriders were posted on "the left and right flanks of the President's car" (a position that would have made a cross-fire more difficult). But, as the films of the motorcade clearly indicate, the motorcycles were posted well to the rear of the President's car and, according to the Dallas police, were positioned there at Lawson's own instructions. After the shooting, when the doors of the School Book Depository were sealed, a man was "trapped inside" who didn't belong there. He was James W. Powell, an Army intelligence agent.

Across the street from the Book Depository is the Dal-Tex Building, and assassination theorists have long speculated that some of the shots on the motorcade could have come from there as well as from the Book Depository. The cops evidently had the same idea, too, because, after the shooting, they picked up a young man who had been in the building "without a good excuse," as the police report puts it. Just who the young man was is impossible to say. While the records show he was taken to the sheriff's of-

fice, his name does not appear, nor does any alibi. Evidently, he just disappeared.

The debate over what did or did not go on at both the grassy knoll and the Dal-Tex Building might well be resolved by a thorough examination of the wounds in President Kennedy's brain. Just for this reason, the brain was removed after the autopsy and "set" in Formalin. Eventually, it was transported, along with other medical evidence, to the National Archives. When Dr. Cyril Wecht, the corner of Allegheny County, Pa., and one of the few independent experts to examine the autopsy photographs and X-rays, sought to locate the brain at the archives, he made a grisly discovery. It, too, had disappeared.

The Oswald Connection

In fixing blame for the assassination, the commission ignored the testimony of eyewitnesses and settled instead on a 24-year-old former Marine named Lee Harvey Oswald. For a country still shaken by the Cold War, Oswald fit the bill perfectly. He was a self-proclaimed Marxist who had, several years before the assassination, "defected" to the Soviet Union. When he returned, he brought a Russian wife with him. As it happened, her uncle was an official in the Soviet Secret Police. Oswald had been born in New Orleans but had grown up in the Dallas area, and it was to Dallas that he returned. One month before the assassination, he had gone to work as a stockboy in the School Book Depository.

Oswald was arrested 75 minutes after the President's murder, as he was sitting in a movie theater. Eventually, he was charged with the murders of President Kennedy and J.D. Tippit, a Dallas police officer who was shot to death on many blocks from the theater within an hour of the assassination. The evidence that Oswald committed either crime is tenuous at best.

Physical evidence linking Oswald to the assassination was strangely inconclusive. A paraffin test turned up traces of nitrates on his hands but not on his cheek, and was ultimately dismissed by both the FBI and the commission as unreliable. A partial palm print was found on the weapon, but police were unable to prove it was Oswald's. The gun itself had been purchased through the mail by an A. Hidell. Dallas police claimed that they found Oswald carrying phony identification for an A. Hidell, yet the accompanying photograph does not look like Lee Harvey Oswald.

The day of the assassination, while rummaging through a garage where Oswald kept some of his things, the police also uncovered two snapshots of Oswald standing in a back yard; a revolver strapped around his hip. In one hand he holds some socialist propaganda literature. In the other he hefts a long, scope-mounted rifle. The FBI, however, was unable to determine whether the rifle was the Carcano. Other researchers, notably Sylvia Meagher, assert that the gun Oswald holds is 2.4 inches longer than the Carcano.

In any case, there is serious question whether the man holding the rifle is Lee Harvey Oswald at all. Several professional photo analysts have flatly branded the picture as a fake. They point out that the V-shaped shadow under the nose is identical in both photos, even though Oswald's head is tilted in one and erect in another. In the first photo Oswald is standing at an angle so oddly out of kilter that, in trying to duplicate it, one invariably falls over. Other photo analysis techniques, such as the red-blue transparency test, find a disparity in the skin tones of Oswald's head and those of his arm and hands. A comparison of the head in the photograph and Oswald's head in booking photos from the Dallas Police Department reveals that the Oswald arrested in Dallas had a rather narrow, pointed chin. The chin of the man standing in the back yard seems decidedly broad and squarish, leading critics of the Warren Commission to speculate that the back yard photo is of another man, with a cropped head shot of Lee Oswald laid atop it just above the chin. Finally,

manufacturer, was standing with his secretary on a concrete pedestal immediately adjacent to the grassy knoll on November 22, 1963. A supporter of the President, Zapruder had brought his 8mm movie camera to record the motorcade. What he saw through the viewfinder instead was the most horrifying moment in modern American history.

Though a few frames are unaccountably missing, and though the film has been spliced twice, the 22-second Zapruder film is startling enough. We see the lead motorcycles turning onto Elm Street, and behind them the President's blue Lincoln. Kennedy is smiling, waving to the crowds. Then, for a few seconds, the car disappears behind a freeway sign. When it emerges, Kennedy has been hit. His hands are clenched, and he is bringing his arms up to his throat. Connally, apparently unharmed, turns back to his right trying to see what has happened. He turns around and is beginning to turn to his left when his cheeks suddenly puff, his hair goes askew, and he is driven downward in the car. In the rear seat Mrs. Kennedy has now begun to lean over her stricken husband, who has begun to fall forward and to the left. The car continues on, almost coasting down the hill. Seconds pass. One one thousand, two one thousand, three one thousand, four one thousand, five one thousand, six. . . . And then, for a fraction of an instant, the President's head is thrown forward a few inches, a blur, lost in the sudden violent impact that tears away the right side of his head in a shower of blood and brains and throws him backward in the car at a speed of 104 miles per hour.

Until recently, these pictures have been seen by a comparative handful of people. *Life* magazine, which bought Zapruder's film for \$25,000, suppressed the fatal frames for reasons of "taste." To most researchers who have seen the Zapruder film, the conclusion is obvious: the final shot comes from the right and to the front, and can only have been fired from the grassy knoll. Josiah Thompson, a Haverford College Professor who was hired by *Life* to work on its investigation of the assassination (and then left when the editors would not accept his evidence of a conspiracy), has studied the Zapruder film more closely and longer than anyone. His conclusion, based on the film, is that there were at least four shots. The first, fired from the School Book Depository, which struck the President in the back. The second, fired from the roof of the nearby County Records Building, which hit Connally. And a final, double impact: a third shot, which hits the President in the back of the head, and a fourth,

which hits him in the head and is fired from the front.

Thompson's theory is based on nothing more than a simple application of Newton's third law of motion: every action has an equal and opposite reaction. When bodies are hit from the rear, they move forward. When hit from the front, they move backward. That is precisely what occurs in the Zapruder film. The commission ignored it. To accept it would have been to say there had been a conspiracy.

Zapruder himself thought there had been one. He later testified that he had heard shots whistle past his right ear. His film, according to some investigators, not only records the assassination but one of the killers. The "figure" is seen in frame 413, toward the end of the film, as the presidential limousine disappears behind some bushes before entering the tunnel. In those bushes is a dark shadow that, to some, appears to be the head and arms of a man, who appears to be pointing a rifle. There are many doubts, even among conspiracy theorists, over whether

Taken together, these happenings form a mosaic of a man in, around, aided and abetted by intelligence agencies through the last six years of his life

the shadow is actually a man. Final proof or disproof awaits image enhancement tests, which are currently being conducted at Cornell University.

A clearer image of a man, pointing what seems to be a gun, appears in a film taken by Orville Nix, who was standing across Elm Street from Zapruder at the time of the assassination. Extreme blow-ups of the 8mm frame, though very hazy, seem to show a man pointing what could be a long-barreled, sighted pistol from behind a cream-colored Rambler station wagon parked behind the grassy knoll. Later, the picture was shown to Lee Bowers, a railroad worker, who witnessed the assassination from a nearby switching tower and told the Warren Commission he had seen unusual "commotion" near the stockade fence just as the shots rang out. "That's exactly what I saw," Bowers said of the picture. A few months later,

Bowers was killed when his car struck a bridge abutment. He had been driving in daylight, on an open road and at moderate speed, when his car suddenly swerved off the side of the road. (Bowers was one of 17 witnesses connected to the Kennedy, Oswald or J.D. Tippit murders to die under strange circumstances within three years of the assassination. Five died of what were officially listed as "natural" causes; the other 12 were victims of murder, accidents or suicide. The actuarial odds of such a string of deaths have been reckoned at 100 trillion to 1.)

The Grassy Knoll and Other Curiosities

If the commission was willing to credit Oswald with extraordinary gifts of marksmanship and mobility, it was not quite prepared to admit he had the power of bi-location as well. Thus, the possibility of an assassin or assassins firing on the motorcade from the direction of the grassy knoll to the right of Elm Street was ruled out.

To rule it out, the commission had to discount the testimony of more than 50 witnesses, nearly a score more than those who reported shots coming from the School Book Depository. By and large, the grassy knoll witnesses were, like Lee Bowers, quite positive about what they saw or heard. More importantly, many of their stories coincided in crucial details, and the details were quite specific. S. M. Holland, who observed the scene from the overpass, reported seeing a puff of smoke near the stockade fence immediately after the shots; Bowers noted the presence of several strange cars in the parking lot in back of the knoll. In one of the cars, Bowers said, a man seemed to be speaking into something that resembled a microphone.

Films back up some of the stories. The Nix film, for instance, shows people running in the direction of the knoll immediately after the shots, while two people on the knoll itself throw themselves to the ground, to avoid being hit by more shots. The film also shows the two motorcycle officers who had been riding behind the presidential limousine dismounting and one of them running up the knoll, gun drawn.

Another policeman who ran to the knoll was Joe Smith, who had been directing traffic at the corner of Houston and Elm when he was summoned by a woman who cried, "They are shooting the President from the bushes." What Smith discovered on the knoll is the most chilling story of all. As he related his story to the FBI: "I pulled my gun from my holster and I thought, 'This is silly. I don't know who I am looking for,' and I put it back.

when the two back yard photographs are laid next to each other, a startling inconsistency emerges. Though the body of the second photo is smaller than the first (since the picture was taken from farther away), the size of the two heads are virtually identical. Either the pictures are fakes, planted to incriminate Oswald in the assassination, or Oswald managed to grow nearly half a foot in the few minutes between the taking of the first and the second pictures.

Against this evidence is the testimony of Marina Oswald, who told the commission she took the pictures. In this and other matters, Mrs. Oswald proved most cooperative; indeed, nearly three-quarters of the evidence against her husband comes from her testimony. Except when it conflicted with its own sequence of events, the commission accepted Mrs. Oswald's testimony at face value, despite numerous warnings from commission lawyers such as Norman Redlich that "Marina has repeatedly lied to the Secret Service, the FBI and this commission on matters which are of vital concern."

The commission's tolerance toward Marina is understandable. There were few other witnesses who could put Oswald at the scene of either murder, and those who could, for one reason or another, were less than wholly credible. Only two witnesses, for instance, claimed to have seen Oswald on the sixth floor shortly before the shots were fired. One was Howard Brennan, a 45-year-old steam fitter who was standing directly across the street from the Book Depository. Minutes before the shooting, Brennan claimed he glanced up and saw Oswald standing in a window on the sixth floor, gun in hand. Later, however, Brennan was unable to pick Oswald out of a police lineup, and the commission itself downplayed the significance of his testimony. The other witness was Charles Givens, one of Oswald's co-workers. Shortly after the assassination, Givens told the FBI that he had seen Oswald on the first floor 40 minutes before the assassination. For the next six months, Givens stuck to that story through several interrogations. Not until commission lawyer David Belin interviewed him on April 8, 1964, did Givens suddenly recall that he had forgotten his cigarettes on the sixth floor and, when he went to retrieve them shortly before noon, spotted Oswald and exchanged a few words with him. Belin, the lawyer who elicited Givens' sudden switch in testimony, recently went to work as chief counsel on the Rockefeller Commission investigating the CIA.

Oswald himself claimed that he

was eating lunch on the first floor of the School Book Depository at the time of the assassination. Within two minutes of the actual shooting, police discovered him calmly sipping a Coke on the second floor. According to the commission, Oswald fled from his sniper's perch, rearranged the shield of boxes he had set up around the window, wiped his fingerprints off the murder weapon, hid the rifle, ran down four flights of stairs, and bought a bottle of Coke—all within 80 seconds.

In 1969 Jesse Curry, who had been chief of the Dallas Police Department at the time of the assassination, said: "We don't have any proof that Oswald fired the rifle. No one has been able to put him in that building with the gun in his hand." No one, Curry should have said, except the Warren Commission.

Secret Agent Man

Almost from the moment of Oswald's arrest, rumors wafted through Dallas and Washington that the accused assassin was an agent for one or more intelligence agencies. The rumors were fed by the fact that the notebook Oswald was carrying with him at the time of his arrest carried the name, license and telephone number of James Hosty, a Dallas-based FBI man who had visited Oswald's household several times. There was no question about the visits. Hosty himself confirmed them, explaining that they were a routine part of keeping track of known subversives. What was more troubling to the commission was the suggestion that Oswald was not only under the surveillance of the FBI but in its employ.

The rumors became formal allegations when Waggoner Carr, the Texas attorney general, passed them on to the Warren Commission. Carr, who said he had gotten his information from reliable informants (they turned out to be on the staff of the Dallas D.A.), said that Oswald collected \$200 every month from the FBI as an informer and that his Bureau identification number was 179.

Carr's information sent shock waves through the commission. Just how seriously the members of the commission viewed the story is shown in a "TOP SECRET" transcript of a closed commission meeting. The recently declassified transcript quotes an alarmed J. Lee Rankin, chief counsel for the commission, saying, "We do have a dirty rumor that is very bad for the Commission . . . and it is very damaging for the agencies that are involved in it and it must be wiped out insofar as it is possible to do so by this Commission." The problem, as commission member and former

CIA Director Allen Dulles quickly notes, is how to go about it, since, if Oswald were an FBI agent, Hoover would claim he wasn't. Or as Dulles aptly puts it: "I think under any circumstances. . . Mr. Hoover would certainly say he didn't have anything to do with this fellow. . . . If he [Hoover] says no, I didn't have anything to do with it, you can't prove what the facts are." When Dulles' fellow commissioners ask him whether he would lie, even under oath, if he were put in the same spot, Dulles bluntly tells them yes, as would any official in the CIA.

For whatever it is worth, then, Hoover and the CIA both dutifully denied that Oswald had ever been their agent. All that remains to contradict them is a series of unlikely events, which, depending on how they are construed, make a powerful case for coincidence or conspiracy.

First, there is the matter of Oswald's Marine record. One of his duty stations overseas was Atsugi, Japan, where he worked as a radar operator and learned Russian, or so it is said, in his spare time. According to those familiar with the workings of the agency, Atsugi is one of the largest CIA bases in the world. In the past, it has been the launching pad for covert operators dropped into Communist China, as well as a base for the agency's U-2s. If Oswald worked at Atsugi, the argument goes, he was almost surely an agency man.

Then, there is the manner of Oswald's leave-taking from the Marine Corps. In September 1959 Oswald applied for a hardship discharge on the ground that his mother had been injured. (A box dropped on her foot at work; she was back at work a few days later.) The discharge was granted three days later—a record time, according to Marine Corps officers. According to the critics, it was the CIA who set the record.

Once home, Oswald spent three days with his mother before leaving for New Orleans, the first stop on a hegira to the Soviet Union. According to the Warren Commission, Oswald paid \$1,500 plus for his passage from money saved from the Marine Corps. But Oswald's bank account showed a balance of exactly \$203. The question is where the rest came from.

Oswald supposedly took a ship to England and made the next leg of his journey—London to Helsinki—by plane. Sylvia Meagher, who matched up the entry date stamped on Oswald's passport in London with the time his commercial flight was said to have departed for Helsinki, found that the plane left a day before Oswald arrived in England. The

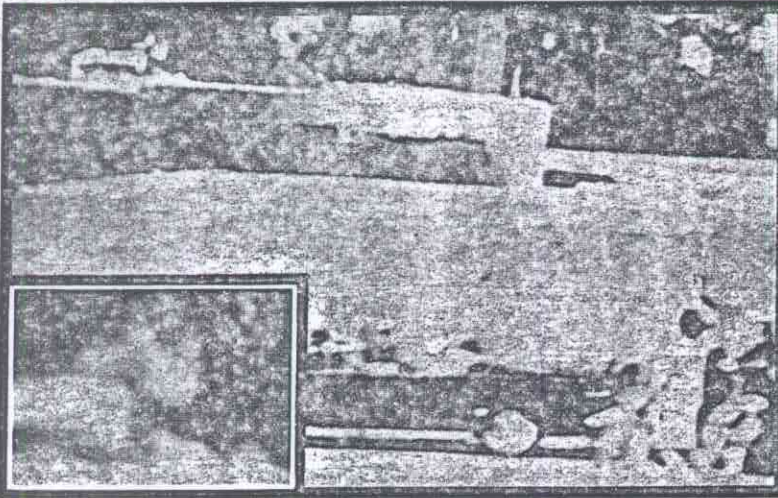

Top, Zapruder frame 413. At the bottom right the head of a man seems to emerge from the leaves. If you look harder, you can see a rifle pointing toward the top left-hand corner—or can you? Bottom, the Nix film. A man, apparently bracing himself on the roof of a car, seems to be aiming a gun in the direction of the President.

only plausible explanation is that Oswald reached Finland by noncommercial means. In the minds of the critics, the CIA made the means available.

Two weeks after his arrival in Russia, Oswald showed up at the American Embassy to make two startling declarations: he was renouncing his American citizenship, and he was going to turn over his knowledge of radar secrets to the Russians. The revelations did not seem to cause a ripple of concern. In any case, when Oswald applied for a new passport two years later, it was routinely granted, along with a loan of several hundred dollars to get home. At the time of Oswald's return to the United States—

1962—the CIA was questioning ordinary tourists about what they had seen in Russia. Oswald, the defector and self-proclaimed betrayer of military secrets, was merely met at the plane by Spas T. Raikin, whom the Warren Commission identified as an official of the Travellers Aid. What the commission did not note is that Mr. Raikin was the former secretary general of the American Friends of Anti-Bolshevik Bloc of Nations, a group with extensive ties to intelligence agencies in the Far East and Europe.

Back in Texas, Oswald and Marina were taken under the wing of Dallas's large and heavily CIA-infiltrated White Russian community. Few people

extended more kindnesses to the Oswalds than George deMohrenshildt, a wealthy oil geologist who boasted that he had worked for French intelligence during the war. DeMohrenshildt took the Oswalds to parties and introduced the young unskilled worker and his bride to his circle of socially prominent friends. Quite possibly, deMohrenshildt also reminisced about the eight-month hiking trip he and his wife had recently taken in 1960 through Central America. Such tale-telling would not be unusual. According to the Warren Commission, deMohrenshildt had already filed a lengthy written and filmed report of his travels with "The U.S. Government." By "happence," the commission writes, the deMohrenshildts' travel itinerary put them in Guatemala City (the jumping-off point for the invaders) at the time of the Bay of Pigs invasion.

Despite the aid of people like the deMohrenshildts, Oswald was apparently unable to get and keep steady work. At least, that was the stated reason why he moved to New Orleans in April of 1963. Oswald did not fare much better on the job market, but he did come in contact with some interesting people. One of them, according to nine witnesses including several law officers, was Clay Shaw. Although Shaw's participation in an assassination conspiracy has never been proven to anyone's satisfaction, Garrison did make a convincing case that Shaw was connected to the CIA, which would hardly be unusual since both New Orleans and the Trade Mart of which Shaw was director are centers of CIA activity in the Caribbean. Moreover, Victor Marchetti, the former executive assistant to CIA Director Richard Helms and author of *The CIA and the Cult of Intelligence*, now quotes Helms as telling his senior staff people at the time of the Garrison trial that Shaw had been a "contract" employee of the agency.

It was in New Orleans that Oswald became involved with the pro-Castro Fair Play for Cuba Committee. Once, while distributing FPCC leaflets, Oswald became involved in an altercation with anti-Castro activists. After a brief brawl, Oswald was arrested for disturbing the peace and hauled into a police station. He made one request: "I want to see the FBI." An agent quickly appeared, and Oswald was released the next day after paying a \$10 fine.

If it is unusual for a self-proclaimed "Marxist" to demand to see the FBI, it is no more out of character than Oswald's other labors on behalf of Castro's Cuba. Some of Oswald's leaflets, for instance, were stamped with the ad-

dress "544 Camp Street." The commission could find no evidence that Oswald ever kept an office at that address, but in its search it found that an anti-Castro group had. That group was the Cuban Revolutionary Committee, a CIA creation put together by none other than E. Howard Hunt.

In late September 1963, Oswald left by bus from New Orleans to Mexico City, where he hoped to obtain a travel visa to Cuba. On October 10 the CIA sent a cable to the State Department and the Office of Naval Intelligence, informing them that a "reliable and sensitive source" had reported that Leon "Henry" Oswald had been seen entering the Soviet Embassy. The CIA said it had reason to believe that this was the same L.H. Oswald who lived in Texas and had once defected to the Soviet Union, and requested that State and ONI furnish pictures of Oswald so that the identity could be confirmed. In its cable the CIA describes Oswald as "approximately 35 years old, six feet tall, athletically built, with a receding hairline." Later, the CIA released pictures of the Mexico City "Oswald." The only resemblance between this "Oswald" and the Oswald arrested in Dallas a month later was the receding hairline. So far, the best explanation the CIA has offered for the affair is that it was a "mixup."

If it were truly a mixup, it bears some explanation. Oswald did, in fact, travel to Mexico City, and his name appears on a visa application filed with the Soviet Embassy. Confirmation comes both from embassy records and from one William G. Gaudet, whose name immediately follows Oswald's on the roster of Mexican travel permits. The Oswald-Gaudet sequence is another one of those coincidences that seemed to have dogged Lee Harvey Oswald throughout his life. For Mr. Gaudet, who lists his occupation as editor of the *Latin American Traveller*, is also an admitted former employee of the CIA.

Another "mixup" that fascinates critics of the Warren Commission occurred during a news conference held by Dallas D.A. Henry Wade while Oswald was in custody. Twice during the conference, Wade announced that Oswald was a member of the "Free Cuba Committee," a serious slip of the tongue, since that committee is a violently anti-Castro group. At last, though, a friendly voice in the back of the room corrected Wade and informed him that Oswald was, in fact, a member of the Fair Play for Cuba Committee. The friendly voice belonged to a strip-joint proprietor named Jack Ruby.

Taken singly, any one of these

happenings can be written off to simple chance. Taken together, they form a mosaic of a man in, around, aided and abetted by intelligence agencies of one sort or another throughout the last six years of his life.

Deduction, however, is not proof. And, in the absence of official explanation, the common-sense linking of a series of incredible occurrences is all that is left to critics of the Warren Commission. The recent disclosures that the FBI was involved in the wholesale planting and buying of double agents in radical groups during the 1960s, coupled with the revelations that the CIA was involved not once but several times in assassination plots against Castro and, according to *Time* magazine, carried out such plots against Francois Duvalier and Rafael Trujillo, provides added impetus to critics who are ready, in any case, to blame most of the world's troubles on the

What Oswald's connections to U.S. intelligence do provide is a rationale for the cover-up that followed the assassination

machinations of U.S. intelligence. Lyndon Johnson himself termed the CIA's operations in the Caribbean "a damn murder incorporated."

All the same, there is, at this moment, not a shred of credible evidence that links either the CIA or the FBI to the planning and carrying out of John Kennedy's murder. What Oswald's connections to U.S. intelligence do provide is a rationale for the cover-up that followed the assassination. For, whether or not Oswald was part of an assassination conspiracy, there was, after his murder, no convenient way for an intelligence agency to explain that, while Oswald had been in their employ, he was not acting at their behest on the 22nd of November, 1963. The "dirty rumors" that so terrified the Warren Commission would always exist. There remained only one solution. The rumors, as Rankin told the commission, "must be wiped out." Clumsily, stupidly, the Warren Commission set out to do just that.

The Ubiquitous Mr. Hunt
Lee Harvey Oswald was not the on-

ly suspect the police arrested that day in Dallas. Nine other men were picked up after the assassination and, after questioning, quickly turned loose. There is a photo of the cops leading away three of the men from the scene. Just who they were is officially unknown; they were released before anyone bothered to take their names. In the Warren Commission report, they are referred to as "tramps." In the photo one of those tramps bears a passing resemblance to Frank Sturgis, one of the Watergate Cubans. The older man looks remarkably like America's favorite spy: author, burglar, black-mailer, assassination devotee E. Howard Hunt.

The resemblance is so striking that some assassination buffs, notably comedian Dick Gregory, have charged that the photograph not only looks like E. Howard Hunt but *is* E. Howard Hunt. The staff of the Rockefeller CIA Commission, headed by David Belin, has obligingly promised to check the matter out. Belin's eagerness to investigate is understandable. For although the photo of one of the tramps looks a bit like Hunt today, it resembles him not at all 11 and a half years ago. More to the point, Hunt has an iron-clad alibi. At the moment John Kennedy was killed, he was having lunch in Washington.

Other details about Hunt and his circle of Cuban friends, however, are not so easily explained. Hunt's path and Oswald's have a curious way of overlapping. The New Orleans address shared by the Hunt Cuban group and Fair Play for Cuba is merely one example. Another is Hunt's presence in Mexico City, as the CIA's acting station chief, when Oswald showed up looking for a visa, the same visit that touched off the mysterious CIA cables about a look-alike Oswald who, in fact, did not look like Oswald at all.

For Hunt to be involved, however peripherally, with Oswald and the events surrounding the assassination is perfectly in keeping with Hunt's image of himself as the master spy and conspirator. In *Give Us This Day*, his account of the Bay of Pigs invasion (in which he served as the CIA's political officer), Hunt writes bitterly of the invasion's "betrayal" at the hands of Kennedy, who, according to Hunt, sought "to whitewash the New Frontier by heaping guilt on the CIA." The betrayal, as far as Hunt and his Cuban comrades were concerned, involved Kennedy's stopping of air support and an assassination attempt on Castro that was to coincide with the landing. The Bay of Pigs was not the first time Hunt recommended assassination, or the last. In 1960 Hunt tried to sell a Castro as-



The familiar photograph of Oswald holding the murder weapon (a *Life* cover in 1964) may be a fake. An enlargement (middle) reveals a much stronger chin than the pointed cleft one in Oswald's police mug shot (far left). Experts believe a photo of Oswald's head might have been placed on top of a photograph of another man just above the chin line.

sassination plot to the Eisenhower administration, but was turned down. In 1965, according to journalist Tad Szulc, Hunt was back with another Castro assassination scheme. This time the plot, in which a bearded Cuban physician named Rolando Cubela was to be the trigger man, went forward, only to be foiled at the last minute by Lyndon Johnson's decision to invade the Dominican Republic. Hunt apparently had these plots in mind when he wrote to the White House in 1972 about his participation in "many illegal conspiracies"—conspiracies that might come to light if funds for his defense and the support of his family were not quickly forthcoming.

Hunt, of course, was not the only anti-Castroite with a fondness for assassination. Frank Sturgis—alias Fiorini—a former gunrunner and casino operator in Cuba, was also an aficionado. Unlike Hunt, Sturgis did come to the attention of the Warren Commission. In tracing Oswald's background, the commission came across stories that Oswald had, both in New Orleans and Miami, tried to infiltrate anti-Castro refugee groups. One story had it that Oswald had tried to become part of an anti-Castro raiding party; another, that he had been exposed as an infiltrator and been in a fight with a Cuban in Miami; yet a third, that he had been in contact with Cuban intelligence. The truth or falsity of any of these tales is less interesting than their source. The Warren Commission placed them at the doorstep of Hunt's old pal, Frank Sturgis.

This time, the coincidence could

be legitimate. The history of pro-Castro and anti-Castro plotting and counterplotting is so tangled that it is virtually impossible to sort out who was doing what to whom and why at any one time. The cast of characters is enormous. There is even evidence that Jack Ruby ran guns for the anti-Castro Cubans. And the list stretches on. Does it mean anything? Could Hunt and Sturgis have been involved in Kennedy's assassination? One can only guess. The Warren Commission failed even to ask the questions.

Too Many Oswalds

For a man who supposedly committed the crime of the century, Lee Harvey Oswald behaved rather oddly. Before the assassination, he seemed to go out of his way to call attention to himself—getting in fights, stirring up a fuss at a shooting range, boasting to a car salesman that he would soon be coming into a "lot of money." These incidents have two things in common. Oswald always identified himself quite loudly, and later the people he had been involved with had trouble identifying him. The incident with the car salesman is especially interesting. First, Oswald did not drive. Second, on November 9, 1963, the day he was supposedly in a car dealership in Dallas, the commission puts him at home in Irving, Texas, writing a letter to the Soviet Embassy. There are other inconsistencies. On September 25, 1963, for instance, Oswald, according to the commission, was riding a bus to Mexico City. Yet, on the same day, a man calling himself Lee Harvey Oswald

walked into the Selective Service Office in Austin, Texas, saying he wanted to discuss his dishonorable discharge.

In 1966 Richard Popkin, a college professor in St. Louis, concluded on the basis of these and other strange occurrences that there were *two* Oswalds, and that the phony Oswald had been employed to frame the *real* Lee Harvey Oswald. Popkin's thesis has a certain tidiness to it. For one thing, it explains how Oswald could have been in two places at once. For another, it shows how a poor marksman could have hit a moving target at a range of 280 feet. For a third, it explains how Lee Harvey Oswald, a man who did not know how to drive, took a car for a test spin at speeds of up to 70 miles per hour.

The "two Oswald" theory also makes some sense out of the CIA's "mix-up" in Mexico City. Interestingly, a man identified as "Leon" Oswald, but fitting the description the CIA issued from Mexico City, showed up in the company of two other men at the home of Sylvia Odio, an anti-Castro Cuban living in Dallas, two months before the assassination. The men who passed themselves off as anti-Castroites said that it would be a good idea to have Kennedy assassinated. Two months later, when Sylvia Odio heard that a man named Lee Harvey Oswald had been arrested for President Kennedy's assassination, she fainted.

Now, Peter Dale Scott, a professor at Berkeley, and one of the most respected and meticulous of the assassination theorists, has come up with a new

wrinkle on the Popkin thesis: not two Oswalds, but several.

Scott bases his conclusion on a study of Oswald photographs collected by the commission. The photograph on the passport Oswald used to enter the Soviet Union is especially striking. It surely shows somebody, but it does not appear to be Lee Harvey Oswald. The chin, facial, nose and bone structure all are wrong.

Scott has also collected the records of Oswald's physical examinations from the time he enlisted in the Marine Corps to the autopsy following his murder. They reveal some seemingly inexplicable dissimilarities. A Marine Corps medical examination conducted on October 24, 1956, for instance, found that Lee Harvey Oswald was 5' 8" tall, 135 pounds, with hazel eyes. Three years later, on September 11, 1959, another Marine exam puts him at 5' 11" tall, 150 pounds, with grey eyes. Of course, Oswald could have grown three inches, gained 15 pounds, and changed the color of his eyes in three years, but it seems unlikely. Altogether impossible is the change recorded on July 13, 1962, during a job physical Oswald took at Leslie Welding Co. That examination shows him to be 5' 9" tall—a loss of two inches in three years. In the arrest bulletin that went out for Oswald on November 22, he was described as 5' 10" tall and weighing 165 pounds—the description that is carried in the FBI files as well. At his autopsy, Oswald was found to be 5' 9" tall, 150 pounds, with grey-blue eyes.

One possible explanation for these differences is that there never was a real Lee Harvey Oswald, or, if there were, he died well before the first Lee Harvey Oswald entered the Marine Corps. From there on, the name and persona of Lee Harvey Oswald became an identity of convenience to be used by an intelligence agency or agencies unknown, a common enough practice among intelligence groups around the world.

Bizarre as the hydra-headed Oswald notion sounds, it was taken quite seriously by J. Edgar Hoover—two and a half years before the assassination. On June 3, 1960, Hoover sent a confidential memorandum to the Department of State, raising the possibility that an imposter might be using the credentials of Oswald, who was then living in the Soviet Union. The Hoover memo sparked other memos within the State Department. None of the correspondence on the possibility of an Oswald imposter was ever forwarded to the Warren Commission. Instead, it was buried in the National Archives and only uncovered recently. W.

David Slawson, a lawyer who checked out rumors about Oswald for the Warren Commission, offers one explanation as to how the file on the counterfeit Oswald managed to disappear. "It conceivably could have been something related to the CIA," says Slawson. "I can only speculate now—but a general CIA effort to take out anything that reflected on them may have covered this up."

It is a chilling thesis, and, like so much about Dallas, it makes just enough sense not to be ruled out.

Who Done It?

There are no answers, of course, only theories, and they range from the unlikely to the obscene. There is a conspiracy to fit every taste and prejudice. The trouble is that, since Dallas, Vietnam and Watergate, few of them can be easily dismissed out of hand. For a time, the CIA itself considered the possibility that Os-

The agency and the mob have enjoyed a cozy relationship since World War II, when the Cosa Nostra protected U.S. ports from Axis sabotage

wald was some sort of "Manchurian Candidate," a sleeper assassin planted to go off on command. The theory, like all the others, made for interesting conversation around the watercoolers at Langley, but, if the CIA ever followed up on the notion, there is no evidence. Within the last few months, a novel, entitled *The Tears of Autumn*, has been published, putting forward the supposition that Kennedy was the victim of a revenge killing for the CIA-approved assassination of South Vietnamese President Ngo Dinh Diem, who was slain in Saigon less than a month before Kennedy went to Dallas. One obvious problem with *The Tears of Autumn* plot is the timing. A few weeks' time seems hardly sufficient to concoct and execute as sophisticated a conspiracy as that which occurred November 22, 1963, in Dallas. Variations of "foreign agents did it" has long held considerable appeal for a number of Americans, including the unlikely duo of Lyndon Johnson and Jack Anderson, both of whom pointed the finger in the direction of Castro. Basically, the argument goes that Castro finally tired of the various U.S. attempts to rub

him out, and, as a self-protective device, launched a pre-emptive strike of his own. The argument, though, flies in the face of Castro's grudging admiration, even fondness, for Kennedy. More to the point, it is difficult to imagine as wily a leader as Castro risking annihilation not only of his regime but of his entire island had he been linked to such a plot.

There is far more disposition, if no more evidence, to blame the CIA, either the top leadership of the agency or an ultra-right faction, which used the agency as a cover. The latter theory centers on the belief that there are really two CIAs: the "good" CIA, composed of the tweedy, analyst types, who tend to be liberal, have gone to good schools and were born somewhere in the Northeast; and the "bad" CIA, the operations boys who are always off smuggling opium, or training secret armies, and who didn't go to such good schools. This thesis is one of the enduring notions about the agency and has been the subject of two minor best sellers, *Last Man at Arlington* (in which the Kennedy assassination provided a backdrop for a number of mysterious murders); and *Six Days of the Condor* (soon to be *Three Days of the Condor*, starring Robert Redford). More seriously, novelist Gore Vidal, writing in *The New York Review of Books*, finds, after an examination of E. Howard Hunt's novels, that Hunt's prose sounds remarkably like that of Arthur Bremer, the would-be assassin of George Wallace. Hunt, of course, was an operations man at the CIA and thus one of the bad guys. Moreover, Hunt has some experience at forging documents connected with assassinations. At the suggestion of Chuck Colson, Hunt fabricated cables linking Kennedy to the assassination of Diem, which Colson then tried to peddle to the press. The attempt backfired, but Vidal finds it more than passing strange that recent assassins—Sirhan, Oswald and Bremer—all showed a penchant for leaving written evidence linking them to their alleged crimes. The question Vidal poses is whether they might have had benefit of a ghostwriter.

For one reason or another, none of these theories—these outrageous slanders—really washes. Besides the lack of evidence, the "CIA did it" theory is simply "too pat," too easily tailored to existing prejudices. The most serious investigators of the assassination are reluctant to point a finger anywhere. They are also the most pessimistic that the real murderers of John Kennedy will ever be found. There is a growing suspicion that Oswald—or whoever he was—was merely the first of many "patsies," a word Oswald chose to describe himself. The CIA,

whom both the right and left have reason to hate, may be the next.

In the classic murder, the assailant must have motive, means and opportunity (another reason to doubt Oswald's guilt; he apparently had none of them). There were many people, groups—and countries, for that matter—that had reason to want John Kennedy dead. But the means and the opportunity must also be present. As a first step, the killers would have to have been able to neutralize the Dallas Police Department (more difficult than it seems). They would have to have been of sufficient stature to dissuade other investigative agencies, notably the FBI and CIA, from going after them, because their exposure would do greater harm to the government and that wonderful catchall, "the public interest," than their actual apprehension. They would have to have had access to skilled, sophisticated trigger men. And that would have taken money, a great deal of money, without subsequent accounting.

As it happens, organized crime fits all these requirements exactly. Certainly, there was motive. The loss of casinos and heroin connections in Cuba because of the regime Kennedy refused to dislodge has been reckoned in the hundreds of millions of dollars a year. Robert Kennedy's pursuit of organized crime had already seriously damaged the mob, especially in New Orleans, the terminus for the Cuban drug connection. And there were indications that the Kennedy brothers were going to hit Nevada next.

As for means, the mob has both the guns and the money to hire them. The opportunity was there for the taking.

The agency and the mob have enjoyed a cozy relationship since World War II, when the Cosa Nostra protected U.S. ports from Axis sabotage, as well as aided in the Allied invasions of Sicily and Italy. The agency returned the favor in various ways. In the late '50s Robert Kennedy, then an investigator for the McClellan committee, encountered a mobster in Las Vegas, who boasted, "You can't touch me. I've got immunity" from the CIA. Incredulous, Kennedy checked; the mobster was telling the truth. Later, during the Vietnam war, CIA aircraft ferried opium out of Southeast Asia; eventually the mob sold it as heroin on American streets. In 1971, during a little-noticed trial of 11 members of a Cosa Nostra family in federal court in New York, the defense called a surprise character witness: the chief of the CIA's local office. The mobsters were not convicted. One indication of the closeness of the relationship between the agency and the mob is that the CIA maintains its larg-

est U.S. office (outside Washington) in little old Las Vegas. "You can bet," says one source close to the agency, "that it isn't for the desert air." The explanation for the CIA-Mafia ties, says one veteran observer of the agency, is that the mob can perform certain "assignments" which the agency either cannot or is unwilling to undertake. In 1961 Robert Kennedy discovered that the agency had put out an assassination contract on Fidel Castro, and that the hit men were from the mob. Kennedy quickly stopped it.

Given that background, some critics of the Warren Commission contend that the mob, after murdering Kennedy, employed its long-standing "immunity" to cut off CIA and other federal investigation of the assassination.

Unlikely as this scenario sounds, it dovetails nicely with the unanswered questions about Jack Ruby. According to the Warren Commission, Ruby was a rather innocent if highly deranged, saloon keeper whose most noticeable

Cuba, crime and the CIA. The three things that everyone connected to the assassination has in common

vice seems to have been a bit of social gambling. The commission flatly rejected the oft-repeated accusation that Ruby had ties to organized crime. The commission ignored testimony before it by a Dallas police detective that he "regarded Jack Ruby as a source of information in connection with his investigatory activities." In short, Ruby was, as Scott notes, a police informant, specifically in the area of narcotics. Scott also points out that the commission ignored a report to the FBI seven years before the assassination that Ruby was providing the okays from the mob for independent operators to move drugs in and out of Dallas. At that, the commission hardly needed to read reports. Ruby's connections with the mob and with the police were common knowledge in Dallas. Even a former Dallas county sheriff detailed Ruby's background; once again, the commission ignored him. Instead, the commission blandly asserted that Ruby's friendships with criminals "throughout his life . . . were limited largely to professional gamblers." Ironically, there was one place where Ruby truly was inter-

ested in gambling: Havana, Cuba.

Cuba, crime and the CIA. Three things that everyone connected to the assassination has in common. Three things the Warren Commission did not want to hear about. They had the killer before the investigation started. He lacked a motive, they would provide it: Oswald, according to the commission, killed Kennedy because of general feelings of inadequacy. At Gerald Ford's insistence, the commission added Oswald being a communist as a reason for murder. Marina testified that it was all a terrible mistake, that Lee really wanted to kill Connally, missed, and shot Kennedy instead. The commission should have added that to the list as well. It makes just as much sense.

It is a confusing, disheartening, ultimately maddening business, this search for the killers of John Fitzgerald Kennedy. The people who look are strange, obsessive types, as people should be who have worked in a grave so long. One man who did some of the earliest and best research into the assassination, and kept repeating that research endlessly, with one listening, finally went mad with paranoia.

Fortunately, the disbelief is spreading. It is the little old ladies, not just the crazies, who are asking questions now. Where once the commission could count on the name and probity of its chairman to certify a preposterous scenario of events, today the mention of Earl Warren's commission brings laughter on college campuses. Ironically, the media have been the last to question the official version of events. The New York Times, which published its own edition of the Warren Commission report and a follow-up volume entitled *The Witnesses* (from which nearly all the dissenting testimony had been carefully excised), continues to stoutly defend the commission's report. Time Inc., which owns the original and hence clearest copy of the Zapruder film, keeps it locked away in a vault. On television the most comprehensive defense of the commission has come from four one-hour specials produced by CBS. The correspondent was that Watergate tiger, David Rather. It may be changing. With Watergate behind them, the investigative reporters are having a second look. As one assassination researcher puts it: "We are one Seymour Hersh story away from new investigation."

America is different now than it was in 1963. Castro is a curiosity. The doubts don't need to be laid to rest. The "dirty rumors" have become all too true. What hasn't changed is the loss. We need to know why. ●