

copy to H. WEISBERG

- 9. 2H85.
- 10. 2H141.
- 11. Fackler ML, Malinowski JA. The wound profile: a visual method for quantifying gunshot wound components. *J Trauma* 1985; 26:522-529.
- 12. DeMuth, WE. Bullet velocity and design as determinants of wounding capability. An experimental study. *J Trauma* 1966; 6:222-232.
- 13. Byrnes, DP, Crockard HA, Gordon DS, Gleadhill CA. Penetrating craniocerebral missile injuries in the civil disturbances in Northern Ireland. *Br J Surg* 1974; 61:169-176.
- 14. Villanueva, P.A., Chapter 19. Cranial Gunshot Wounds. In: Ordog, Gary J. *Management of Gunshot Wounds*. New York: Elsevier, 1988.
- 15. 5H82.
- 16. 7HSCA,171.
- 17. 1HSCA,404.

timing of the shots fired at President Kennedy by analyzing the blurred frames in Abraham Zapruder's film of the assassination. In practice it is largely a sort of cross-examination of Mr. Zapruder's neuromuscular system. It is, in a way, the testimony of his unconscious.

Of course, Zapruder gave conscious testimony as well. He had heard two loud shots and two only. The first, he said, struck the President and made him stop waving. The second blew open his head. Zapruder always believed both of these shots came from behind him. He gave the Secret Service that opinion the very first evening: "According to Mr. Zapruder, the position of the assassin was behind Mr. Zapruder." [1] Zapruder would later repeat all this under oath. "I thought I heard two...I never even heard a third shot." [2] Where did the shots come from? Wesley Liebeler stubbornly tried to make Zapruder deny he had an opinion. Driven to the wackysyntax of "Yes we have no bananas," Zapruder held his ground:

Zapruder: No, I also thought it came from back of me.

Liebeler: Perhaps the shot had come from behind you?

Zapruder: Well, yes.

Liebeler: From the direction behind you.

Zapruder: Yes. [3]

But after November 22, except in his nightmares, Abraham Zapruder stopped viewing his movie. *Life* had it and was studying it intensely. By its first post-assassination edition *Life* had the bare essentials.

Life confirms Zapruder.

The first shot, *Life* said, strikes Kennedy. As he emerges from behind a sign his wave "turns into a clutching movement toward his throat." Then Connally turns and by what's now called frame 244, "is himself hit by a bullet." [4] The third, fatal shot to Kennedy, striking between frames 312 and 313, is all too obvious. *Life* judged it too gory and printed a frame just before.

But in its next two editions *Life* went much, much further. Under the heading "END TO NAGGING RUMORS" it published a stunning frame-by-frame account of the murder:

SCIENTIFIC SLUMMING WITH LUIS ALVAREZ

by
Gene Case

Of all the heavyweight reputations summoned over the years to shore up the government's Lone Assassin Theory, none compares to that of Doctor Luis Walter Alvarez. But Dr. Alvarez's "blur analysis" demonstrates the perils even a Nobel physicist encounters when he descends to the ethical and intellectual level of a state-sponsored hoax. The result of this scientific slumming is not just that Dr. Alvarez fails to prove the dubious hypothesis he was enlisted to prove. He damned near disproves it.

What is blur analysis?

"Blur analysis" attempts to make gunshots reverberate from a silent film. It seeks to determine the

Gene Case
70 West 69th Street
New York, NY 10023

"The first (shot) strikes the President, 170 feet away, in the throat...74 frames later the second fells Governor Connally...48 frames after that the third, over a distance of 260 feet, hits the President's head." [5]

The President, Life said, was struck by a bullet in the front of the throat. He was struck at Zapruder frame 312 minus 48 frames minus 74 frames. He was struck in the throat at frame 190.

"74 frames later" places Connally's wound at frame 264. That is clearly too late. Life knew better. Remember, it had already placed Connally's wound no later than frame 244. Most likely "74 frames later" and "48 frames later" (counts which were meaningless to Life's writers) were inadvertently flip-flopped. When they are reversed they put Connally's reaction at an obvious place: frame 238, which Life had approximated earlier. That explanation can be disputed. What's indisputable is that within a week, the film's closest analysts concluded Kennedy was shot in the front of the throat at frame 190. (Life had a secret ally in this opinion: John Connally. After studying the film to fix the instant of his own wounding—he finally settled on frame 234—Connally would tell the Warren Commission in April that "he felt the President might have been hit by frame 190." [6] The Commission couldn't find room for these eleven words among the ten million it printed.)

But Life never published the frame in which "the first shot strikes the President in the throat." That frame was badly blurred, as were the frames right after. It would take two years to find out why.

Harold Weisberg invents blur analysis.

It was the indefatigable Harold Weisberg who figured it out:

"Beginning with frame 190, this film suddenly becomes fuzzy. Nothing had changed—the exposure was the same, the sun had not gone behind the clouds—the change was in Zapruder. He was no longer holding the camera as steady." [7]

Zapruder shuddered and his camera moved sideways. The lens, remaining open for some 30 milliseconds, admitted this moving image to the

film. The film recorded a blur. This happened twice—first at frame 190 and then again at frame 313, when the fatal shot struck.

It was a brilliant piece of detective work. Unconscious Zapruder corroborated conscious Zapruder! At the same time it corroborated Life's analysis, John Connally's hunch, the timing of Phil Willis' fifth photograph, the testimony of Glen Bennett and the testimony of bystanders too numerous to list. Two shots had come from behind Zapruder at frames 190 and 313, making him shake his camera. The first made the President stop waving. The second blew open his head.

The Lone Assassin Theory was already in trouble. In November of 1966 it received a near-fatal blow. Life magazine turned against it, devoting its cover and 12 full pages to an extremely belligerent Zapruder film critic, John Connally.

The first conspiracy theorist speaks out.

John Connally had been the very first conspiracy theorist. In an instant he'd known that those first shots came from different rifles:

"I was covered with blood and the thought immediately passed through my mind that there were either two or three people involved or more in this...because of the rapidity of these two, of the first plus the blow that I took..." [8]

He'd tried to stay out of that jump seat in the first place. His dyseptic scowl is the one constant in virtually every image from Dallas. Three years later he was still adamant. The "one-bullet theory," he told Life, was crap. Life agreed, and screamed "CONCLUSION: THE CASE SHOULD BE RE-OPENED." [9] Life would get its new investigation alright, but the investigative body would be a bit of a disappointment.

It was CBS.

The investigation aired June 25, 1967. For the first 40 minutes Walter Cronkite and Dan Rather brought little to the party. The usual witnesses were rounded up, then promptly ignored. "Nothing is less reliable than the testimony of an eyewitness," Cronkite explained. [10] You could forget about ear witnesses, too, for Dealey Plaza was "a bowl certain to

cause echoes." (The idea that witnesses in Dealey Plaza were bamboozled by echoes is summarily disproved in a study buried in the HSCA Report, "Accuracy of forced choice responses as to TSBD or Knoll." A Dr. Wightman and a Dr. McFadden, blindfolded, attempted to "localize" the origins of 17 gunshots. "In the first sequence, Dr. Wightman correctly localized all 17 shots, and Dr. McFadden missed only 1." Dr. Wightman's infallibility fell off slightly over the next two sequences [maybe his ears were ringing]; Dr. McFadden's didn't.) [11] Could Oswald have hit Kennedy? Marksmen were assembled, given Mannlicher Carcanos to practice with, then unleashed on a sled-like target. A few actually hit it, which was proof enough for CBS. Finally, after the last commercial break, the network sprang the only new idea it had. It was Harold Weisberg's old idea, blur analysis. But such a brilliant idea deserved a more intimidating genius to invent it.

Luis Alvarez invents blur analysis.

The new inventor was to be Luis Walter Alvarez. Luis Alvarez had designed a necessary part of the A-bomb. He had observed Almagordo and Hiroshima in real time. He had invented Ground Controlled Approach radar. He had built the particle accelerators that led to the discovery of leptons and quarks and muons. His obituary and portrait would grace a front page of the New York Times. He was a genius and genius does not go unnoticed. Just as the Warren Commission was cranking up, Alvarez was summoned to the White House and there, for "contributions to national defense" among other things, he was awarded the new National Medal of Science by the new President Lyndon Johnson. [12]

There is evidence that Johnson may have requested another contribution. Alvarez's obituary in the Washington Post reads:

"In 1963 Dr. Alvarez assisted the Warren Commission...He demonstrated through principles of physics that one person could have fired all the shots that hit Kennedy and Texas Gov. John Connally." [13]

The same claim was made in the Los Angeles Times. Did he? A source at the Post told me only

"I assure you we didn't make it up." But Alvarez's name isn't in the Warren Report index nor did he ever mention "assisting" Warren, and these newspapers were probably just exercising their zealously-guarded, constitutionally-protected right to get things wrong. Luis Alvarez's version goes like this:

In Berkeley in the fall of 1966 he "found himself in repeated discussions with his graduate students concerning the Warren Report." [14] When Professor Alvarez got home the day before Thanksgiving what should he find in his mailbox but Life with John Connally on the cover, demolishing the Warren Report with the biggest, clearest reproductions of the Zapruder film ever seen.

Alvarez pored over Life. He focused on one frame, 227. Here, points of sun-glare on the limousine were suddenly stretched out into smears of light. This, he surmised, was Zapruder's "startle response" to a gunshot. It wasn't caused, as Harold Weisberg had thought, by Zapruder's "emotions at what he saw" but by his neuromuscular response to a loud noise. Come Monday, in dingy Warren Report versions of the Zapruder frames which appear to have been photographed through a fizzing glass of Alka-Seltzer, Alvarez found more of these light smears and measured each and every one. He found patterns. A friend called a friend, Richard Salant, who happened to run CBS News. CBS flew its sudden star scientist east to view the Zapruder slides in the National Archives and answer the last, vexing question. Never mind whether or why—exactly when did Lee Oswald shoot Jack Kennedy?

Alvarez closes the case (first time).

Until now, two things had been taken for granted. Oswald wouldn't have tried to shoot through the tree beneath him, because he didn't have to. And he couldn't have fired his rifle twice in less than 2.3 seconds, because FBI-man Robert Frazier had testified under oath that he was "firing this weapon as fast as the bolt can be operated." [15]

Luis Alvarez chucked both of these assumptions right out the Texas School Book Depository window.

ALVAREZ SCENARIO ONE

Shot	Film blurs at
frame 186 (misses)	frame 190
frame 223 (hits Kennedy & Connally)	frame 227
frame 313 (kills Kennedy)	frame 318

There was a fleeting hole in the foliage at frame 186. Oswald had fired through it, missed, worked the bolt, aimed again and fired exactly two seconds later at frame 223, hitting the President in the back and making a perjurer out of Robert Frazier.

What had happened to the first bullet? It had drilled itself into a tree branch and stuck there. CBS sent a man shinnying up the tree with a metal detector to find it—he couldn't, though CBS vowed to return later and X-ray the tree. (Fortunately for the network, they never found that tree-trapped bullet—if they had, how would they explain James Tague?)

CBS was not modest about what Alvarez had wrought. The three shots from Oswald's rifle were "as ineradicably marked in the Zapruder film as if he had caught the bullets in flight." [16]

Alvarez fails high school physics.

The truth is, had this been a high school physics exam, Luis Alvarez would have flunked it. His solution ignored rudimentary physical laws. Chief among these was the fact that sound travels at a finite speed—1123 feet per second. (The speed of sound varies slightly with temperature and altitude. This is the figure used by the HSCA.) That is 61 feet per Zapruder film frame. Zapruder was standing 270 feet away from the window at which Oswald allegedly crouched. It took 4.4 film frames for the sound of Oswald's muzzle blast to reach Zapruder.

Alvarez and CBS allowed a fifth of a second—4 film frames—for the "relatively sluggish neuromuscular system" [17] of a 58-year-old man to react to the gunshot. He heard the shot, they said, at frame 186. But the blast actually occurred 270 feet away nearly five frames earlier. Five frames plus four frames was nine frames. The trigger had to have been pulled nine frames earlier. It had to be pulled by frame 181.

There was no hole in the foliage at frame 181.

Blur analysis reared back and bit its masters. It proved that there was no shot through the "hole" at frame 186.

Nor were the smears of light in frame 227 any more satisfying. CBS assured us that "in the frame ahead and again in the frame beyond, they were individual dots." [18] The dots blurred for just one frame. That was 1/18th of a second. A spasmodic neuromuscular motion involving body extremities that begins, reverses itself and comes to rest in 1/18th of a second isn't humanly possible. Why was the background of this frame so remarkably clear? Didn't it appear that Zapruder had momentarily stopped tracking the limousine—nothing more?

Most disturbing of all was the last violent shudder at frame 318. When you looked closely, it was obvious that it began back at frame 313. But that was the same frame in which the President's head blew open. How could that be? What happened to the "relatively sluggish" human reaction time? Didn't that prove an earlier shot? Or even a double-hit?

Alvarez maintained a discreet distance from CBS' conclusions. On camera he said little. What did it mean? It meant that there were three shots. "I showed," he wrote later, "that the first shot had indeed missed and that the shot in the throat was the second." [19] From a serious scientist this was inexcusable braggadocio. He'd proved nothing about hits or misses.

But CBS was ecstatic. Their polling indicated that viewers of the program had been impressed and convinced.

The nuts rise from the ashes.

The next year Luis Walter Alvarez won the Nobel Prize for physics. But 1968 was a dark year. President Johnson was driven from office. Draft cards, flags, cities burned. A cynicism toward those in power set in. Warren Report critics were carriers of this cynicism. Alvarez became contemptuous of them. They were "sometimes called assassination buffs," he learned. From then on he called them nothing else.

"I have found the buffs' books...both unconvincing and incredibly dull...A single theme ties them together—that those in power

are congenital liars, as is supposedly demonstrated further in Vietnam and Watergate." [20]

— On the back of Alvarez's autobiography Arthur Clarke was blunter. The buffs, Clarke said, were "nuts." Alvarez had "shot them down." But the nuts came back. They lobbied into existence a House Select Committee on Assassinations. Its Chief Counsel was recruited by Mark Lane, the chief nut. The Warren Report was under siege again. Alvarez buttonholed a buff he respected. What, he asked, was for "his fellow buffs" the most persuasive argument for a conspiracy? [21] It was that Kennedy's head snapped backward after the fatal shot. In a flash Alvarez had an explanation—his "jet effect" theory—"I solved the problem...on the back of an envelope, as I sat in solitary splendor in the beautiful suite that the St. Louis hotel management supplied me in my capacity as president of the APS" [22]—in which the President's head became a jet engine and his brain tissue became jet fuel. This theory would confound the buffs. He would publish it. While he was at it, he would dust off blur analysis. **Alvarez closes the case (second time).**

Luis Alvarez divorced CBS. Their marriage had produced a "simplified and not too convincing report." He couldn't explain blur analysis "to a lay audience and in a short space of time." [23] This time he would write for his peers. He would need room. The *American Journal of Physics*, a bleak little monthly edited for physics teachers, gave it to him. "A physicist examines the Kennedy assassination film" appeared in September, 1976. It was an intimidating piece of work. (A footnote at the end of the article whispers "This work was done with support from the U.S. Energy Research and Development Administration." It may be as innocent as "I want to thank Mom for letting me keep the tadpoles in the bathtub during this experiment." On the other hand, would an agency of the U.S. government have "supported" a physicist who looked at the Kennedy assassination film and found two gunmen there? The President at this time was Gerald Ford.)

Luis Alvarez opened by erasing all human memo-

ries of the assassination. They were worthless. He endorsed a *Scientific American* essay—"Eyewitness testimony is unreliable...an eyewitness to a crime is being asked to be something and do something that a normal human being was not created to be or do."; [24] and added a personal "highlight"—"My reasons for preferring physical evidence to the recollections of even the best witnesses are highlighted by noting that the Governor was not even aware that he had received bullet wounds in his wrist and in his thigh. [25]

Governor Connally had been shot to within an inch of his life. He was in shock. His rib was shattered, his lung punctured; he was covered with blood and believed he was dying. That in his death throes he failed to do a complete medical inventory of his wounds says absolutely nothing about the reliability of "the recollections of the best witnesses." But it was good strategy for Alvarez to try to strike "normal human beings" from the equation, because his new scenario required that the assassin behave in ways no normal or abnormal human being had ever behaved before.

Boldly shooting where no man has shot before.

The original excuse for shooting through the tree—the gap in the greenery—was declared inoperative. "Tree shmee" sneered the demented marksman. He blasted right through the fluttering leaves, worked the bolt with superhuman speed and a scant two seconds later dashed off another shot, again making his decision to shoot while his target flickered behind the foliage. Having exploited to the hilt this golden opportunity to shoot through a tree, he then relaxed. He took a leisurely 5 1/2 seconds to squeeze off his last shot.

Oswald was compelled to this weird behavior by the data shown on the chart on the next page. (Fig. 1) This, Alvarez said, was the very plot he "made and showed to my friends at CBS." [26] Again he'd "caught the bullets in flight." But this time they flew earlier. He'd refined blur analysis. A startle response to a gunshot didn't consist of just one blur or "jiggle." It consisted of a "pulse train" of three or four jiggles. "Most people have a peak in their jitter power spectrum at about 3 cycles/sec." [27] The

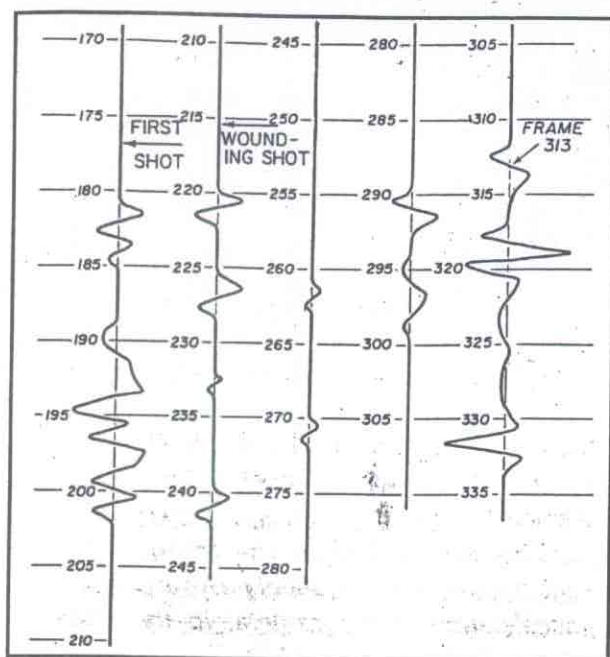

Figure 1.

jiggles in each pulse train fall a third of a second apart. Alvarez identified three of these pulse trains. He lengthened Zapruder's reaction time to five frames. He then back-timed the shots that much from the onset of each train of jiggles:

ALVAREZ SCENARIO TWO

Shot	Film blurs
frame 177 ("first shot"—it misses)	frame 182
frame 215 ("wounding shot")	frame 220
frame 313 (fatal shot)	frame 313

"Shot" could mean when the shot was fired, or it could mean when the shot reached its target. Judging from Alvarez's five-frame delay, it meant neither. "Shot" was when Zapruder heard the shot:

Shot fired	Shot reaches target	Z. hears shot	Film blurs
frame 173	frame 174	frame 177	frame 182
frame 211	frame 212	frame 215	frame 220
frame 311	frame 313	frame 313	frame 313

Is this a reasonable interpretation of Alvarez's data?

Imagine that you've been blindfolded and told to

draw five long rapid straight lines. While you're drawing these lines you're startled by two gunshots. The blindfold's removed and you're shown the lines you drew. Where are the gunshots you heard? It's quite obvious where they are. They're where the straight line turns into jagged convulsive spasms—first in the 190's, again in the 310's. But, you're told, there were three gunshots. Where's the third? Well then, it must have been at 290. No, that wasn't a shot, that was a siren. The third shot's somewhere else—find it. How can you? Nowhere else is there anything resembling the spasms in the 190's and 310's. The rest of the jiggles are different in degree and kind. They don't look like human reactions at all. They're short, disconnected, mechanical—as if maybe the table you were drawing on got bumped.

This is the conclusion a reasonable observer must reach. And when the House Select Committee on Assassinations did its own blur analysis two years later, it's the conclusion they did reach:

"This analysis indicated that blurs occurring at frames 189-197 and 312-334 may reasonably be attributed to Zapruder's startle responses to gunshots." [28]

"An original jiggle analysis, performed without knowledge of the results of the acoustical evidence, showed strong indications of shots occurring at about frame 190 and at about frame 310..." [29]

Alvarez dodges the bullets.

But Luis Alvarez wasn't coming to a conclusion from the data. He was coming to the data from a conclusion. Two loud shots were no good. It must be three. They must come from the same rifle. The data must be massaged so that it rendered up three equally loud shots. It could be done, because he had so many jiggles to work with.

In all he plotted some 40. But that wasn't all of the blurs. That was just the changes in blur lengths. That was just the "angular accelerations of Mr. Zapruder's camera." In between were "meaningless streak lengths" which Alvarez didn't deign to measure. They were continuations of other blurs. There were lots of these, too.

A decade earlier with great fanfare it had been

announced that three mountains had been found in Tibet. Now it was obvious that Tibet was mostly mountains. Besides the "motion blurs" there were "out-of-focus" blurs. The out-of-focus blurs were "almost cyclic, suggesting film motion about the focal plane." [30]. Not only did Abraham Zapruder have a "peak in his jitter power spectrum of 3 cycles/sec." Abraham Zapruder's camera had a peak in its focus spectrum of 3 cycles/sec. Throughout the film blurry sequences began with eerie regularity every six or seven frames. The "pulse train" which Alvarez first picked up at frame 182 had actually been chugging along since almost the start of the film: there were blurs at frames 158 and 165 and 171 and 177. "Subjective quality categorizations" were later done on 72 successive frames. Twenty-seven frames were judged "good" or "fair." But 45 were judged "blurred," "badly blurred," or "hopeless." [31] That was 63%. Sixty three percent of the frames in the Zapruder film were blurred. Blur Analysis was a poker game in which 63% of the cards were wild. Wherever you wanted a blur you could be confident in finding one. Any player could make up any hand he wanted.

The blur that shouldn't be there.

But there was one blur where Luis Alvarez didn't want a blur. It was that vexing premature jiggulation at the instant of the head shot.

"The impact of the bullet can be seen in frame 313, and there isn't enough time available for the relatively sluggish neuromuscular system to have produced the observed torque on the camera axis." [32]

"Not enough time" was an understatement. There was no time. When the shutter closed on frame 312 the President's head was intact. Twenty-three milliseconds later the shutter opened for frame 313. In this frame the head is exploding and the camera is already shaking. A startle response couldn't explain that.

But Alvarez' first instinct hadn't been to solve the assassination with startle responses anyway. His instinct had been to solve it with shock waves.

"I thought I detected a deformation of the Presidential flag under the influence of a shock

wave generated by a nearby bullet." [33]

"Flag analysis" had turned out to be one of Luis Alvarez' least lasting contributions to science.

"When I saw the full set of frames, it was clear that the flag was simply flapping in the breeze." [34]

Now he turned again to shock waves. The jiggle at 313 was a jiggle to the right. It

"could have been caused by a direct interaction of the shock wave from the bullet that hit the President in frame 313 with the left-hand side of Mr. Zapruder's camera." [35]

Was Luis Alvarez saying that the shock wave from Oswald's bullet physically knocked Zapruder's camera sideways? He was.

"The obvious shot in frame 313 is accompanied immediately by an angular acceleration of the camera, in the proper sense of rotation to have been caused directly by shock wave pressure on the camera body.

[36]

Shock wave pressure on the camera body?

Like almost all rifle bullets, Mannlicher Carcano bullets are supersonic. Supersonic objects generate a shock wave, a pressure front which carries energy outward from the object's flight path. The shock wave fans out in a conical shape called a Mach cone. The cone expands at the speed of sound and is perceived as sound—for example, the sonic boom of a supersonic jet.

But the shock wave's intensity is a function of the mass of the object that causes it. It also falls off rapidly as it radiates from its path of origin. Seventy-five feet away it is 15 times weaker than it was five feet away. "Oswald's bullet" weighed a third of an ounce. Abraham Zapruder stood 75 feet from the path of this tiny missile. That a bullet weighing a third of an ounce and ending its flight 75 feet away would generate a shock wave knocking sideways a three-pound camera gripped in both hands was to me ridiculous.

We search for the elusive shock wave.

I rounded up a friend with a rifle and we drove to a quarry. We hung a piece of cardboard from a stick and fired bullets past it, as close as three feet. It

didn't move. We tried tinfoil. It didn't move. We built a mop-like device of hanging strings. They didn't move. Granted, these tests were crude. Could they be cruder than Enrico Fermi's?

"Fermi had almost instantly measured the explosive yield of the first atomic bomb by observing how small pieces of paper which he 'dribbled' from his hand were suddenly moved away from 'ground zero' by the shock wave."
[37]

We switched to an old Winchester Special with a muzzle velocity closer to Oswald's. Still there was nothing. Finally we drove to the Albany Gun Show. At the booth of "Dave" we got lucky. Under a torn shard of cardboard with the crayon message "PRICED TO SELL" was a Mannlicher Carcano. At \$59 it was the cheapest gun in the house. Dave pointed us to "Becker." Becker sold us 6.5mm Carcano cartridges hurling 156-grain bullets at a muzzle velocity of 2428 feet/second. (The world War II surplus ammunition which Oswald was alleged to have used was about 5% slower than ours. The bullets were about 3% heavier).

Now we had an excellent replica of "the fateful rifle of Lee Oswald." We did our tests over again.

The cardboard, the tinfoil and the strings were unimpressed. The shock wave from a Mannlicher Carcano bullet passing three feet away does not flutter cardboard, tinfoil or string, much less the body of a movie camera 75 feet away.

Dr. Luis Walter Alvarez, Nobel laureate, winner of the National Medal of Science, the Medal of Merit and the Einstein Medal, was blowing it out his ass. **But something did happen at 313.**

Nevertheless the image in frame 313 is grossly distorted. Something is happening here, and it isn't just a blurring of the frame.

First, look closely at the round spots of light along the chrome roll bar in the frame before, 312. (Fig. 2, left) They are spots of sun glare on what appear to be handholds. They resemble the little bulbs over a star's dressing-room mirror.

Now look at the same spots of glare in frame 313, (Fig. 2, right) The spots are tripled. There are three images side by side.

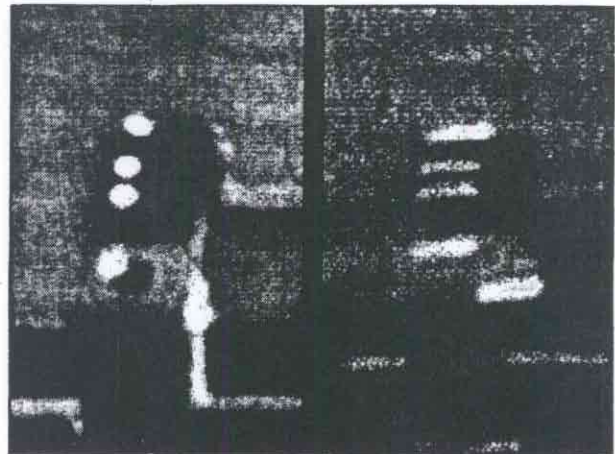

Figure 2. The effect of a shock wave on the image of a passing bullet.

Alvarez could have been right about the cause—a shock wave—but wrong about the nature of the "interaction." The "interaction" could be a vibration in the shutter mechanism or elsewhere in the workings of the camera. Firing a rifle past a VHS camcorder, I was able to record the image of the shock wave of a passing bullet. It is an extreme undulation of the picture which lasts three video frames — 3/30ths of a second. Of course an 8mm film movie camera is a very different mechanism. But vibration of the shutter in Zapruder's camera, or of the film itself, is a plausible explanation for this triple imaging.

A shock wave at 313 could only have come from behind Zapruder.

Assume for the moment that at frame 313 you are looking at the effect of a shock wave passing through Abraham Zapruder's camera. Is there anything to be learned from this? There is. Alvarez has disproved his own theory.

Shock waves, recall, travel outward from a bullet flight path at the speed of sound. It is a simple geometric problem to calculate how long a shock wave from "Oswald's" bullet path would take to reach Abraham Zapruder 75 feet away. The answer is that it would take 60 milliseconds—1.1 Zapruder frames.

The shock wave from a bullet on that flight path striking the President's head at the end of frame 312 or after would not be visible until frame 314. (At the

1995 COPA Conference, a "bloodstain pattern analyst," Ms. Sherry Pool Gutierrez, exhibited high-speed close-up photography of "forward spatter" and "back spatter" generated by bullets passing through various objects. Back spatter was visible while the bullet was still inside the object—within a millisecond—and had radiated several inches while the bullet was still visible in the photograph. The absence of spatter in frame 312 indicates the President is not hit before the closing milliseconds of that frame). If frame 313 is the image of a shock wave interacting with Abraham Zapruder's camera, that bullet had to pass much closer to Zapruder than 75 feet. It had to come from behind Zapruder.

We do a reality check.

A Bell & Howell "Director Series" Zoomatic 8mm movie camera like Abraham Zapruder's weighs 3 lb. 1 oz (I have one). It must be gripped firmly in both hands, keeping one finger pressed down hard on the "run" button, or else it stops filming. A person trying to film with it as a Mannlicher Carcano rifle is fired a few feet away will feel an ear-splitting

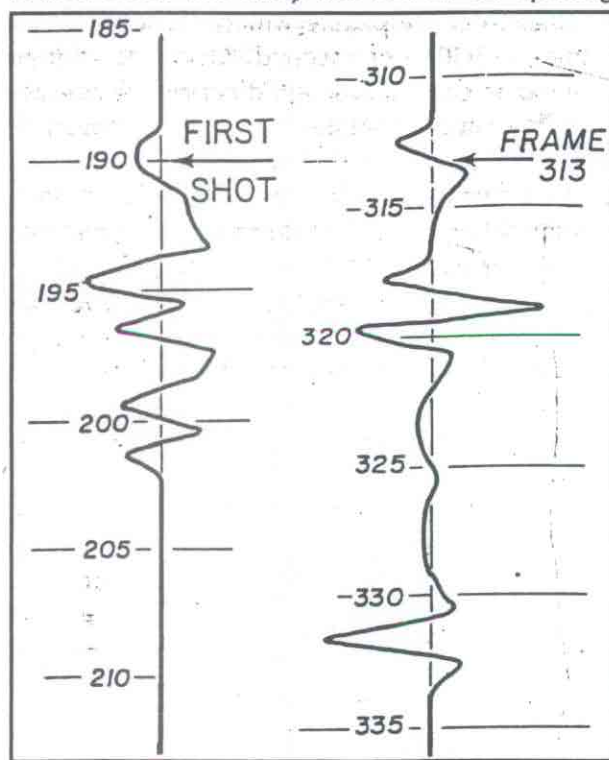

Figure 3.

explosion in the "painful" to "immediately dangerous" sound level range—120 decibels or so. (Of course, there's no way to know what sort of weapon was used on the knoll). The person will jump. If the shooter moves 20 feet behind and fires right past the person, the sound remains very loud and sharp. The person will shudder. If the shooter moves 270 feet away and fires at a target 75 feet away, the person may or may not shudder. From here the sound seems duller, more bass and much less loud. That's in accord with theory—each time distance is quadrupled, loudness should fall off by roughly half. These purely subjective tests were done in a farm field where the loudest ambient sound was the caw of a crow. In Dealey Plaza there were ten of man's noisiest inventions: motorcycles. Four of the motorcycles were three times closer to Abraham Zapruder than was the alleged source of the shots. **A long-missing jiggle completes the puzzle.**

If the spasms at frames 190 and 313 were caused by gunshots from the same source behind Zapruder, we should expect the plots of these sequences to be similar. In Fig. 3 they are aligned. The main difference is that there's no fourth "peak" in the first spasm—after frame 202, Alvarez' plot straightens out like a West Texas highway. In fact, it shouldn't straighten out. The reason Alvarez didn't find any "smears of light" on the limousine after frame 202 was because he couldn't see the limousine. It's obscured behind the sign. Worse, Alvarez never saw frames 208 through 211 at all. They weren't in the Warren Report, and in 1966 were still missing from the Archives. In these frames Zapruder's camera is jiggling. Frame 203 is very blurred. The entire sequence from 208 to 211 is blurred, especially 210. Josiah Thompson had access to LIFE's film; frame 210 is one of six blurred frames he calls attention to [38]. (Thompson and LIFE ridiculed Alvarez' "jiggle theory of the assassination," conceding only that the blur beginning at frame 313 was a genuine startle response. But in one case Thompson's detective's instincts come up somewhat short of Sherlock Holmes'. He wrote, "Zapruder himself can't be of much help here—he only heard two shots." Like that dog that couldn't be of much

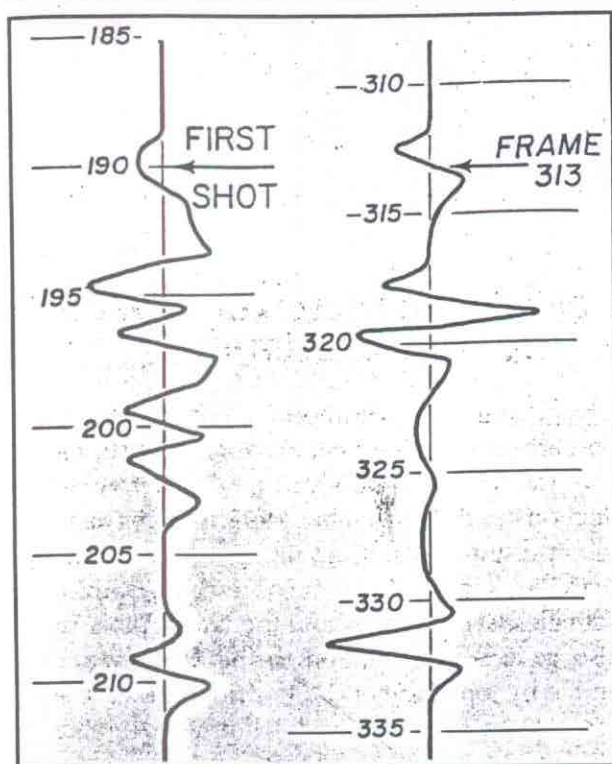

Figure 4.

help because it didn't bark). William Hartmann's plot shows a high peak at frames 209 and 210 [39]. Frank Scott's doesn't but under these frames is the notation "NA"—"not available"—he didn't see them either [40]. When we put this jiggle cycle at frame 210 where it belongs, (Fig. 4) the sequences match. **We are back where we started.**

Two loud shots whizzed past Abraham Zapruder, vibrating his camera and startling him. The first hit the President in the throat and made him stop waving. The second blew open his head.

Postscript from Planet Posner.

In Gerald Posner's *CASE CLOSED* the author makes it appear that blur analysis supports his timing of the shots when in fact blur analysis lays waste to it. This is typical. There is a recklessness to Gerald Posner's lying that is new to mainstream publishing. His guard isn't even up. Evidently he's been assured that the fix is in. He is also scientifically illiterate and so, perhaps, unaware how stupid some of the things he writes are. Posner says

unambiguously that the first shot was fired between frames 160 and 166 [41]. On planet Posner, thunder precedes lightning and reactions precede actions. So when did Zapruder react to this shot? Naturally, before it was fired.

"The first significant blur was at frames 158–160, just at the time Oswald had to fire to avoid losing his target under the tree" [42].

When was the second shot?

"Careful analysis points to the impact of Oswald's second shot at frames 223–224." [43].

And when did Zapruder's camera start to jiggle from this shot? Need you ask?

"The jiggle between 220–228 is caused by the second shot [44]."

But then, maybe, Abraham Zapruder's jiggling camera was a signal to Oswald that it was time to shoot.

*This work was done with invaluable support from Will Lutz Jr. of Ancramdale, New York, who made the rifle tests possible. Bill Meissner of Oakland Park, Florida, graciously loaned the camera. Milicent Cranor made many contributions to the article; her criticism was infuriating and invariably correct.

Notes

1. Secret Service Agent Max Phillips memorandum dated 9:55 P.M. Nov 22, 1963, Warren Commission Document 87, folder 1.
2. Warren Commission Hearings and Exhibits, vol. 7, p. 570. References to this source cited hereafter in format: 7H570.
3. 7H570.
4. *Life*, Nov. 29, 1963, pp. 24,25.
5. *Life*, Dec. 6, 1963, p. 52F and undated "Memorial Edition"
6. Memorandum in unnumbered Warren Commission file, National Archives; quoted in Olsen & Turner, *Journal of Forensic Sciences*, Oct. 1971, p. 413.
7. Harold Weisberg, *Whitewash*, p. 47.
8. 4H132–3.
9. *Life*, Nov. 26, 1966, p. 53.
10. "The Warren Report," CBS, June 25, 1967. The

- program can viewed at the Museum of Television & Radio, 25 West 52nd St., New York. A transcript is in Stephen White's Should We Now Believe the Warren Report?
11. House Select Committee on Assassinations (HSCA) Report, Vol. 8, p. 147.
 12. New York Times, Jan. 14, 1964.
 13. Washington Post, Sep. 3, 1988. Milicent Cranor discovered this surprise.
 14. Luis Alvarez, Adventures of a Physicist, p. 243.
 15. 3H407.
 16. White, Should We Now Believe the Warren Report?, p. 77.
 17. Luis Alvarez, "A physicist examines the Kennedy assassination film," American Journal of Physics, Sep. 1976, p. 816. Cited hereafter as Alvarez, APEKAF.
 18. "The Warren Report," CBS.
 19. Alvarez, Adventures of a Physicist, p. 243.
 20. Alvarez, Adventures of a Physicist, p. 243.
 21. Bob Dean is the source of this historical footnote, which he heard at a conference at which the "buff" spoke.
 22. Alvarez, APEKAF, p. 819.
 23. Alvarez, APEKAF, p. 814.
 24. Robert Buckhout, Scientific American, Dec. 1974, p. 231.
 25. Alvarez, APEKAF, p. 814.
 26. Alvarez, APEKAF, p. 816.
 27. Alvarez, APEKAF, p. 816.
 28. HSCA Report, p. 47.
 29. HSCA Report, p. 83.
 30. D.H. Janney memorandum to HSCA, June 27, 1978, p. 3, National Archives.
 31. D.H. Janney, "Table 1".
 32. Alvarez, APEKAF, p. 816.
 33. Alvarez, APEKAF, p. 815.
 34. Alvarez, APEKAF, p. 815.
 35. Alvarez, APEKAF, p. 816.
 36. Alvarez, APEKAF, p. 817.
 37. Alvarez, APEKAF, p. 815.
 38. Josiah Thompson, Six Seconds in Dallas, p. 293.
 39. HSCA Report, p. 20.
 40. HSCA Report, p. 24.
 41. Gerald Posner Case Closed, pp. 323, 477.

42. Posner, Case Closed, pp. 322-3.

43. Posner, Case Closed, p. 477.

44. Posner, Case Closed, p. 323n.

UPDATES: NEW DEVELOPMENTS ON PREVIOUS ARTICLES

Nacirema. A little more is known about the obscure group of Atlanta-based terrorists called The Nacirema, mentioned in "J.B. Stoner, An Introduction" in the November 1995 issue. The same report of the House Committee on Un-American Activities that in 1965 "exposed" Ku Klux Klan activities (see "Oswald and the Nazis," this issue) also gave some attention to the Nacirema. An article by John Herbers, "Offspring of Klan Called Violent" in the New York Times, November 2, 1965, p. 1 reports that the Nacirema was chartered in Georgia on 6/1/61 and that two "illiterate" members named William Anderson and William Crowe from Decatur GA had instructed Robert Shelton and other Klansmen in bombing techniques in 1961. Aficionados of "coincidence" may note that both an Anderson and a Crowe named William were among the close associates of Jack Ruby in 1963: Crowe was aka Bill DeMar, who did a "mind-reading" act at the Carousel; and Bill Anderson was a piano player at the Carousel who (again, coincidentally) lived directly across the street from Ruth and Michael Paine in Irving.

Another reference to the Nacirema is contained in a December 1962 FBI memorandum reporting an interview with Dan Campbell, a private investigator for Guy Banister (FBI # 105-70374-1749, furnished courtesy Jerry Shinley). Campbell said he "was interested in running down the Hate Movement in New Orleans" and that, pursuant to this interest, had learned that a meeting was to be held at a cock fight arena in LaPlace LA for the purpose of attempting to merge three groups: the "neo-Nazi National" (see the New Orleans Nazi reference in "Oswald